

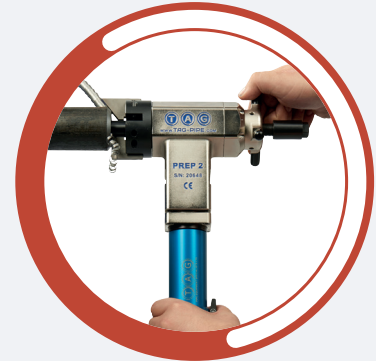

PIPE EQUIPMENT SPECIALISTS LTD

PREP 2 PIPE BEVELLING $\frac{1}{2}$ " to $1\frac{1}{2}$ "

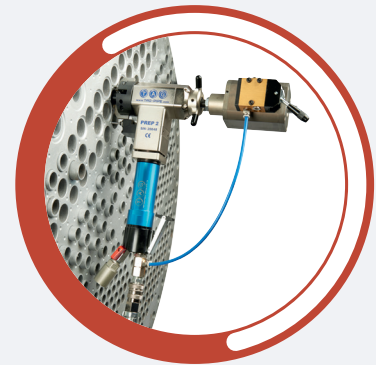

www.TAG-PIPE.com

Copyright © 2017 TAG PIPE EQUIPMENT SPECIALISTS LTD. All rights reserved.

Tel: +44 (0)1869 324 144
E-mail: sales@tag-pipe.com

RANGE: 23 to 42mm i/d (Optional from 12.5mm i/d)

- **Functions:** External Beveling
Internal Beveling
Elbow Beveling
Facing
Counter-boring
Weld Removal
J-Prepping and facing of Tubeplate
- **Materials:** Any kind of Steel
and Exotic Alloy
- **Power:** Pneumatic / Electric / Battery
(110v or 220v)

The smallest in our range of i/d locking, direct in-line feed end prep machines. The PREP 2 is small, lightweight, yet powerful, in electric, battery (110v or 220v) or pneumatic drive form.

A 4 jaw tool holder (chuck) allows use of up to 4 form tools to enable weld preparation of thin wall tube, or heavy wall pipe.

Simultaneous external & internal beveling and facing of tubes is simple, ideal for accurate repetitive work.

Its size, power, and functionality, make it extremely popular in high volume heat exchanger work, tube facing, weld removal, and J-Prepping of the tube plate. Also used extensively on Power Station Shutdowns for boiler panel bevels.



FEATURES & ADVANTAGES

The PREP 2 is torque reactive. This means that the pipe or tube does not have to be fixed to be bevelled, making it particularly useful on-site, in maintenance and repair situations. This is due to the design and strength of the thru shaft system that locks to the bore of the pipe.

The Jaw system itself consists of 3 equilaterally positioned machined jaw segments, retained and locked on an inner, 'grooved' expansion shaft.

These grooves keep the jaws held securely in position, unlike other systems that use a metal or rubber bands for jaw retention.

As the expansion nut is tightened, the jaws expand, locking tightly, and square to the bore of the pipe.



POWER OPTIONS:

PNEUMATIC



PART NO. TP2P

ELECTRIC



PART NO. TP2E

BATTERY



PART NO. TP2B

ACCESSORIES & OPTIONS:

REDUCED SHAFT

12.5 - 23mm



PART NO. TP2RSK

ELBOW SHAFT



PART NO. TP2ESK

AUTO LOCK

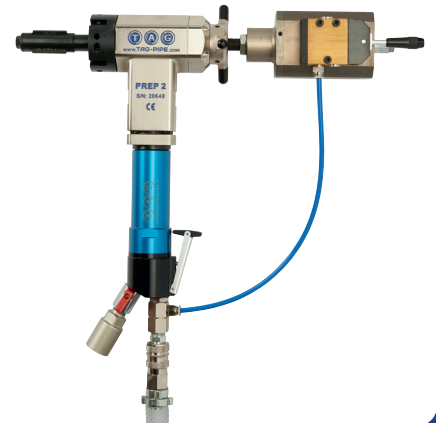

PART NO. TP2ALD

RATCHET HANDLES



PART NO. TP2AHK

FEED STOPPER



PART NO. TP2FSK

FILTER LUBRICATOR



PART NO. AFL1

PREP 2 TECHNICAL FEATURES:

| DESCRIPTION | MEASUREMENT | PNEUMATIC | ELECTRIC | BATTERY |
|---------------------------|-------------|-----------------|-----------------|-------------------|
| Part Number | - | TP2P | TP2E | TP2B |
| Locking tube range | mm (i/d.) | 23 - 42 | 23 - 42 | 23 - 42 |
| Recommended working range | inch (o/d.) | ½ - 1½" | ½ - 1½" | ½ - 1½" |
| Idle speed | rpm | 0 - 215 | 5 - 250 | 160 |
| Torque | kgm/nm | 2.9 / 29+ | 4.0 / 39+ | 6.5 / 64+ |
| Length of axial feed | mm | 24 | 24 | 24 |
| Max operating temperature | c° | 55 | 55 | 55 |
| Max acoustic radiation | dB | 75 | 75 | 75 |
| Pneumatic motor power | hp | 1.3 | - | - |
| Air consumption | cfm | 28 | - | - |
| Air working pressure | psi | 90 | - | - |
| Air hose connection | inches | ½" | - | - |
| Electric motor power | watt | - | 720 | 1300 |
| Voltage | volt | - | 110 / 220 | charger 110 / 220 |
| Frequency | Hz | - | 50 / 60 | charger 50 / 60 |
| Unit weight | kg | 4.8 | 5.5 | 5.7 |
| Packing dimensions | mm | 560 x 410 x 120 | 560 x 410 x 120 | 560 x 410 x 120 |
| Packing weight | kg | 13.5 | 14.5 | 15.5 |

PACKAGE

All units are supplied complete with all locking jaws to cover the full range of the machine. Service tools, drawings, instruction manual and warranty certificate and protective metal carrying case.



DIMENSIONS

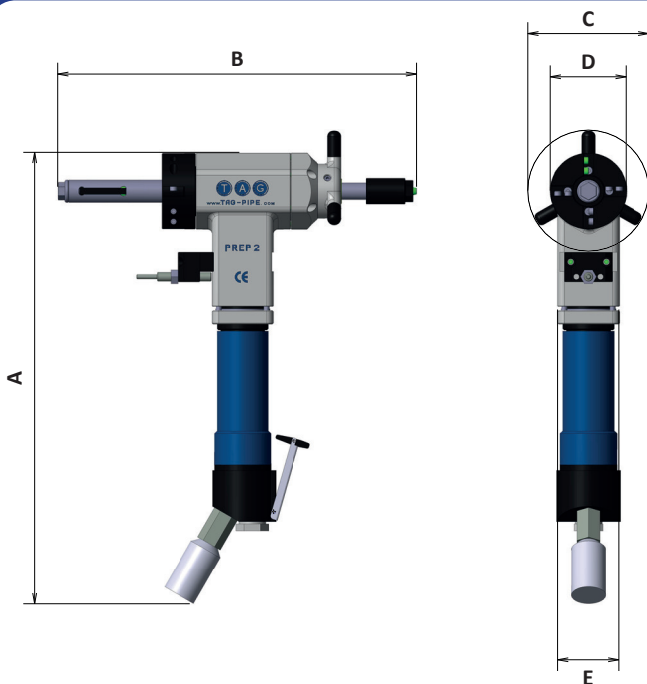

| DIM | PNEUMATIC | ELECTRIC | BATTERY |
|-----|-----------|----------|---------|
| A | 400mm | 430mm | 470mm |
| B | 316mm | 316mm | 316mm |
| C | 106mm | 106mm | 106mm |
| D | 67mm | 67mm | 67mm |
| E | 54mm | 72mm | 72mm |

EXAMPLES OF COMMON CUTTING TOOLS

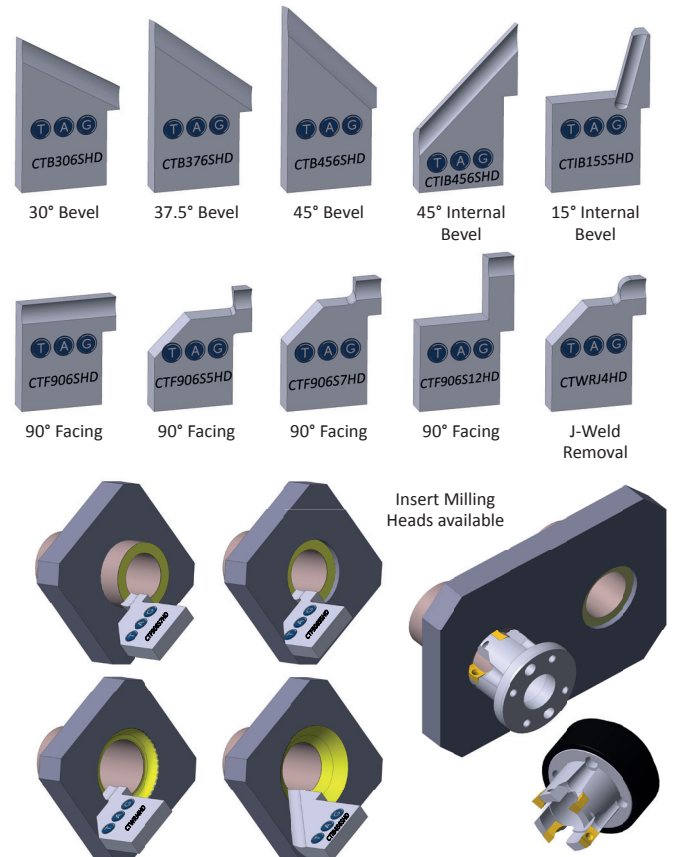

All shapes, sizes and angles available



PIPE EQUIPMENT SPECIALISTS LTD PRODUCTS INCLUDE:

PIPE BEVELLING MACHINES



PIPE CUTTING MACHINES



PIPE ALIGNMENT CLAMPS

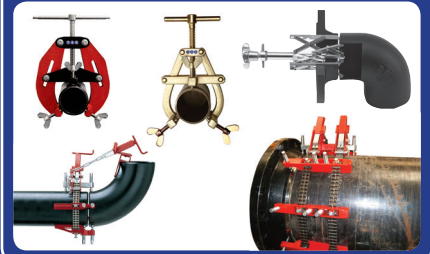

PIPE STANDS AND ROLLERS



PIPE PURGING EQUIPMENT



PLATE BEVELLERS

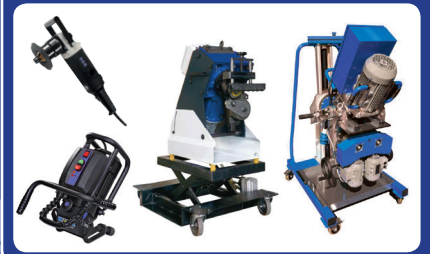

North America

Europe

Asia

Middle East

India

Africa

South America

Australia



TAG Head Office

TAG PIPE EQUIPMENT SPECIALISTS LTD
Unit 15 & 16 Grendon Industrial Estate, Grendon Underwood,
Aylesbury, Buckinghamshire, HP18 0QX England
Tel: +44 (0)1869 324 144 E-mail: sales@tag-pipe.com
www.TAG-PIPE.com

Your Local Distributor

Overseas Branches



USA Branch

TAG PIPE EQUIPMENT SPECIALISTS INC
527 Michigan Street, South Houston
Houston, Texas 77587, USA
Tel: +1 713 660 1427
E-mail: sales-usa@tag-pipe.com



Europe Branch

TAG PIPE EQUIPMENT SPECIALISTS BVBA
Mosten 13, 9160 Lokeren
Belgium
Tel: +32 486 46 62 93
E-mail: sales-europe@tag-pipe.com



Middle East Branch

TAG PIPE EQUIPMENT SPECIALISTS FZE
Al Ittihad Street, P.O. Box 3763
Dubai, United Arab Emirates
Tel: +971 (0)50 680 3107
E-mail: sales-me@tag-pipe.com



India Branch

TAG PIPE EQUIPMENT SPECIALISTS PVT
Plot No. PAP 3, D 3 Block,
Chinchwad, Pune 411 019
Tel: +91 20 6573 4333
E-mail: sales-india@tag-pipe.com



Asia Branch

TAG PIPE EQUIPMENT SPECIALISTS PTE
Yinhe Bridge West, Beichen District
Tianjin, China
Tel: +86 139 2001 5417
E-mail: sales-asia@tag-pipe.com

Our company policy is one of continuous improvement. Products may change or vary from those illustrated.

Copyright © 2017 TAG PIPE EQUIPMENT SPECIALISTS LTD, All rights reserved.